

Vehicle Type	FIRE FIGHTING TRUCKS, ROAD SERVICE TRUCKS
Gearbox Type	VERTICAL MEDIUM DUTY SPLIT SHAFT

Product Code	UARA.805
Revision No-Date	01 / 23.06.2018

Product Views

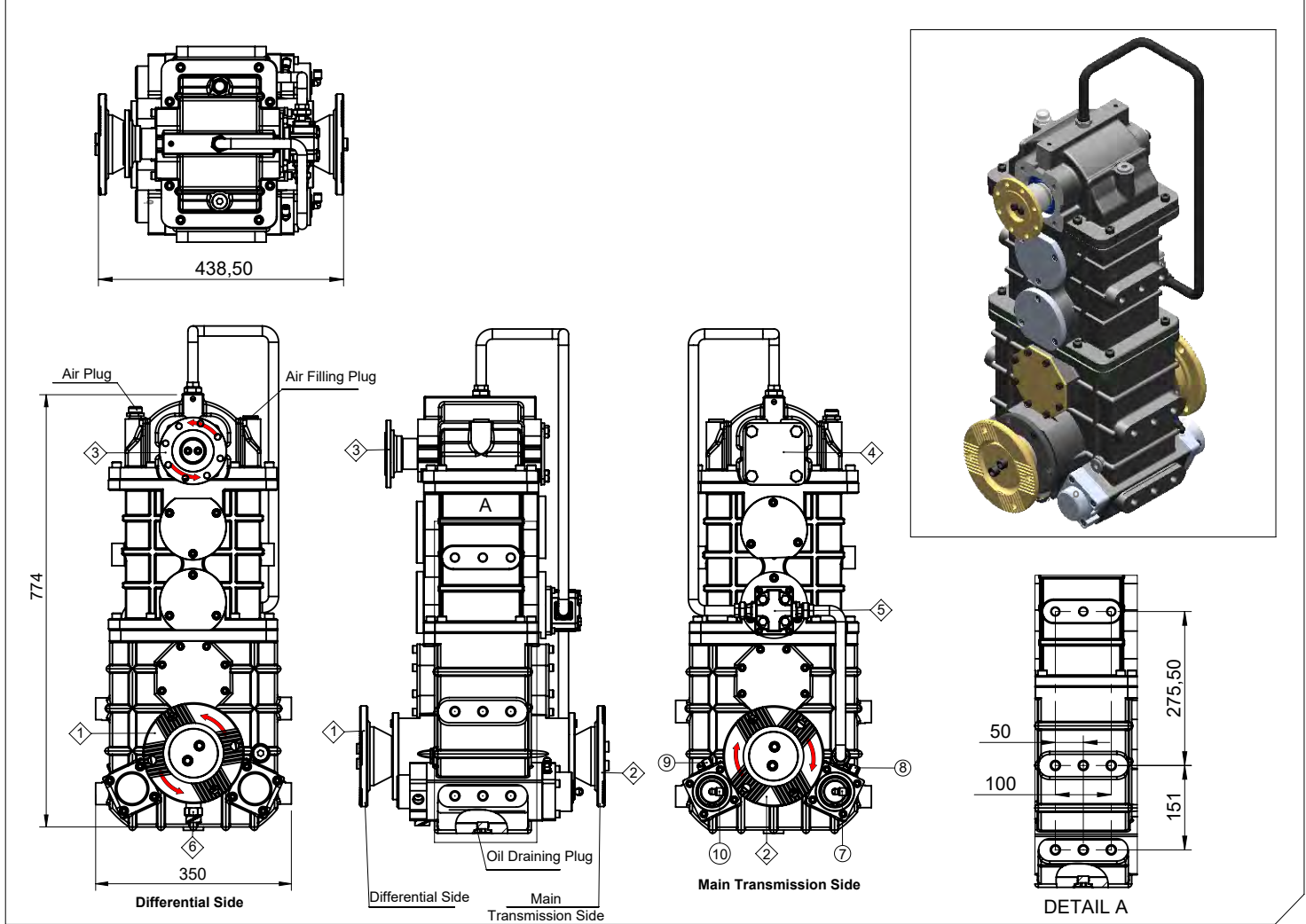

Component Details

- 1 : ISO 8667 - ISO 7646 - ISO 7647 Standard Flange
- 2 : ISO 8667 - ISO 7646 - ISO 7647 Standard Flange
- 3 : ISO 8667 - ISO 7646 - ISO 7647 Standard Flange
- 4 : 2. Output (Optional)
- 5 : Lubrication Pump
- 6 : RPM Counter Sensor (Optional)

- 7 : Air Inlet, Engage Main Drive
- 8 : Air Inlet, Disengage Main Drive
- 9 : Air Inlet, Engage PTO Outputs
- 10 : Air Inlet, Disengage PTO Outputs

Technical Details

Outputs	Max. Values	Max. rpm	Internal Ratio	Mounting Type	Control Type
1 & 2	800 kgm		1/1	Split Shaft	Pneumatic
3 & 4	135 kW	2300 - 2800 rpm	1/1.2 1/1.84 1/1.4 1/2.13		Weight
5 & 6				175 kg	Same as Input



Ofis
 Tel. +90 312 354 05 39
 Fax +90 312 354 34 59
 7. Sokak No: 9
 Ostim / ANKARA
 e-mail: info@kozmaksan.com.tr

Fabrika
 Tel. +90 312 267 39 71
 Fax +90 312 267 38 72
 AOS. 1. OSB. Erkunt Cad. No: 6
 Sincan / ANKARA
 Website: www.kozmaksan.com.tr